

PORTAVALIGIA SPECIFICO - SPECIFIC CASE HOLDER
PORTE-VAUSE SPÉCIFIQUE - SPEZIFISCHER KOFFER-TRÄGER
PORTA-EQUIPAJE ESPECÍFICO

YAMAHA T-MAX 500cc '08-'11
YAMAHA T-MAX 530cc 2012

ISTRUZIONI DI MONTAGGIO - MOUNTING INSTRUCTIONS
INSTRUCTIONS DE MONTAGE - BAUANLEITUNG - INSTRUCCIONES DE MONTAJE

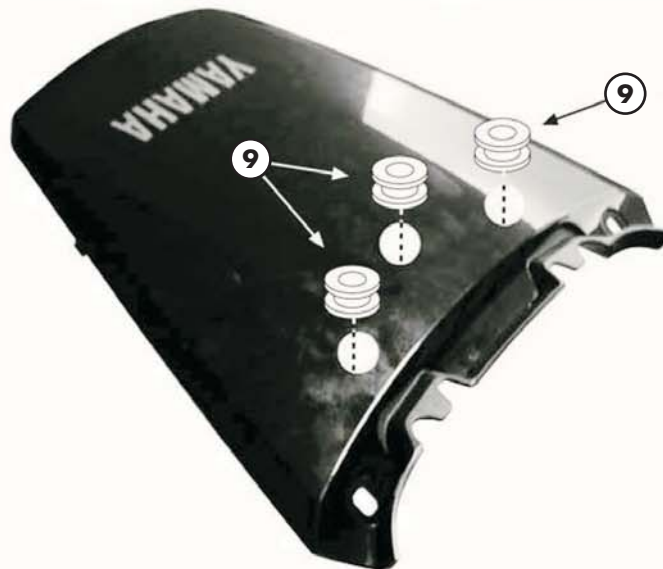

SOLO PER TMAX 2008-2011
ONLY FOR TMAX 2008-2011
SEULEMENT POUR TMAX 2008-2011
NUR FÜR TMAX 2008-2011
SÓLO PARA TMAX 2008-2011



PORTAVALIGIA SPECIFICO - SPECIFIC CASE HOLDER
PORTE-VALISE SPÉCIFIQUE - SPEZIFISCHER KOFFER-TRÄGER
PORTA-EQUIPAJE ESPECÍFICO

YAMAHA T-MAX 500cc '08-'11
YAMAHA T-MAX 530cc 2012

ISTRUZIONI DI MONTAGGIO - MOUNTING INSTRUCTIONS
INSTRUCTIONS DE MONTAGE - BAUANLEITUNG - INSTRUCCIONES DE MONTAJE

SOLO PER TMAX 2012
ONLY FOR TMAX 2012
SEULMENT POUR TMAX 2012
NUR FÜR TMAX 2012
SÓLO PARA TMAX 2012

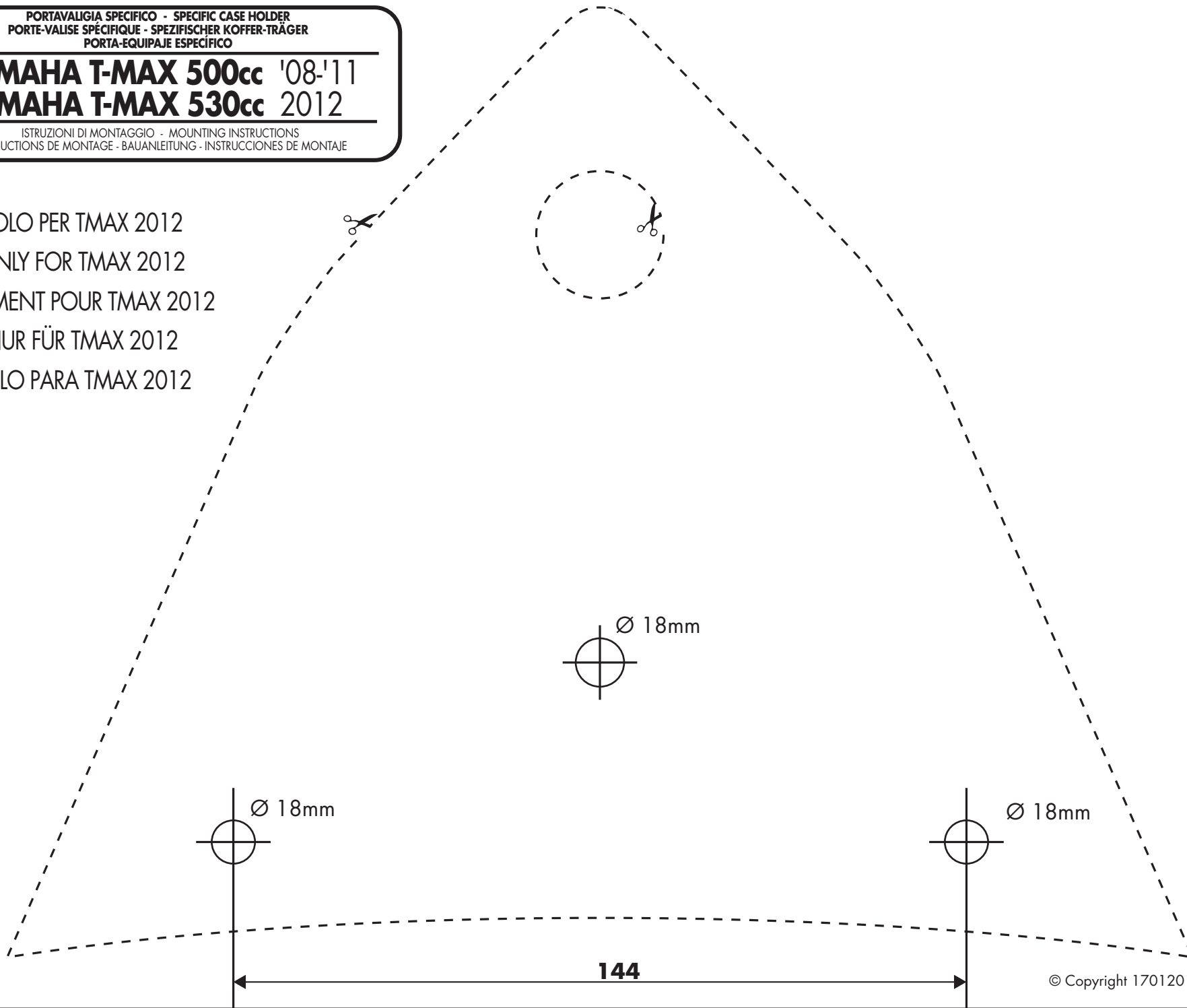

PORTAVALIGIA SPECIFICO - SPECIFIC CASE HOLDER
 PORTE-VALISE SPECIFIQUE - SPEZIFISCHER KOFFER-TRÄGER
 PORTA-EQUIPAJE ESPECÍFICO

YAMAHA T-MAX 500cc '08-'11 YAMAHA T-MAX 530cc 2012

ISTRUZIONI DI MONTAGGIO - MOUNTING INSTRUCTIONS
 INSTRUCTIONS DE MONTAGE - BAUANLEITUNG - INSTRUCCIONES DE

1



SUPPORTO
 SUPPORT
 HALTERUNG
 SOPORTE

Q.TY n.1

2



PIASTRA
 M5
 PLATE
 PLATINE
 PLATILLA

Q.TY n.1

3



VITE TE M8x35mm
 SCREW M10x30mm
 VIS M10x30mm
 SCHRAUBE M10x30mm
 TORNILLO M10x30mm

Q.TY n.2

4



VITE TCEI M6x25mm
 SCREW
 VIS
 SCHRAUBE
 TORNILLO

Q.TY n.4

5



VITE TBEI M8x40mm
 SCREW
 VIS
 SCHRAUBE
 TORNILLO

Q.TY n.1

6



VITE TBEI M8x80mm
 SCREW
 VIS
 SCHRAUBE
 TORNILLO

Q.TY n.2

7



DADO A.B. M6
 BOLT M6
 ECROU M6
 MUTTER M6
 TUERCA M6

Q.TY n.4

8



COPRIFORO
 Z621
 BOLT CAP
 CACHE TROU
 STOPSLOCK
 TAPA AGUJERO

Q.TY n.6

9



GOMMINO
 Z1827
 FAIRLEADER
 CHAUMARD
 GUMMI
 GOMA

Q.TY n.3

10



RONDELLA Ø8x14mm
 WASHER Ø8x14mm
 RONDELLE Ø8x14mm
 SCHEIBE Ø8x14mm
 ARANDELA Ø8x14mm

Q.TY n.5

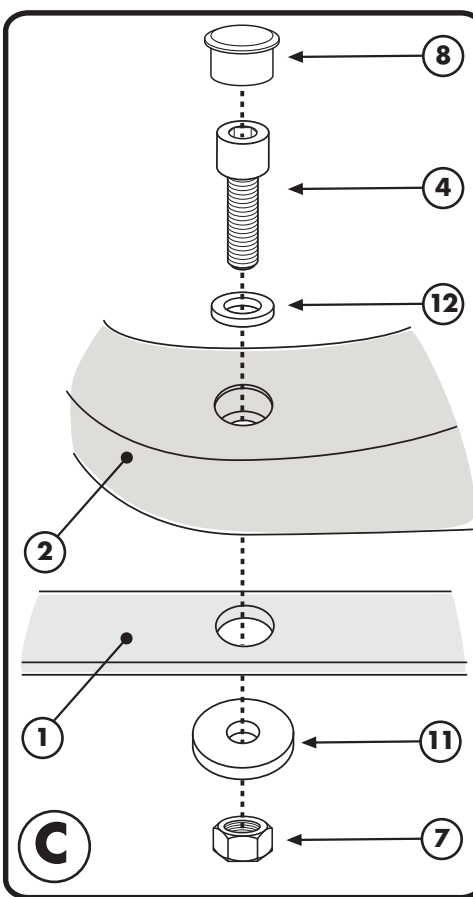

11



RONDELLA Ø6x18mm
 WASHER Ø6x18mm
 RONDELLE Ø6x18mm
 SCHEIBE Ø6x18mm
 ARANDELA Ø6x18mm

Q.TY n.4

12



RONDELLA Ø6mm
 WASHER Ø6mm
 RONDELLE Ø6mm
 SCHEIBE Ø6mm
 ARANDELA Ø6mm

Q.TY n.4

13



DISTANZIALE Ø14x55mm
 Foro Ø8,5mm
 V685
 SPACER
 ENTRETOISE
 DISTANZSTUECK
 DISTANCIADOR

Q.TY n.2

14



DISTANZIALE Ø22x16mm
 Ribassato Ø14x12mm
 foro Ø8,5mm V742
 SPACER
 ENTRETOISE
 DISTANZSTUECK
 DISTANCIADOR

Q.TY n. 1

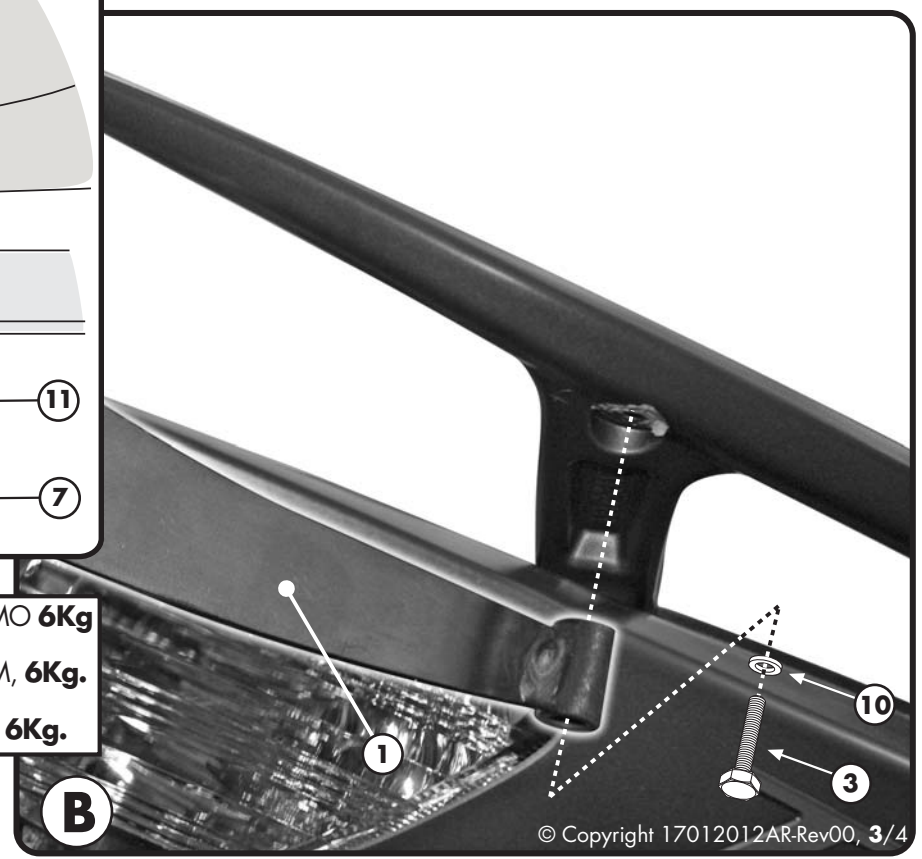
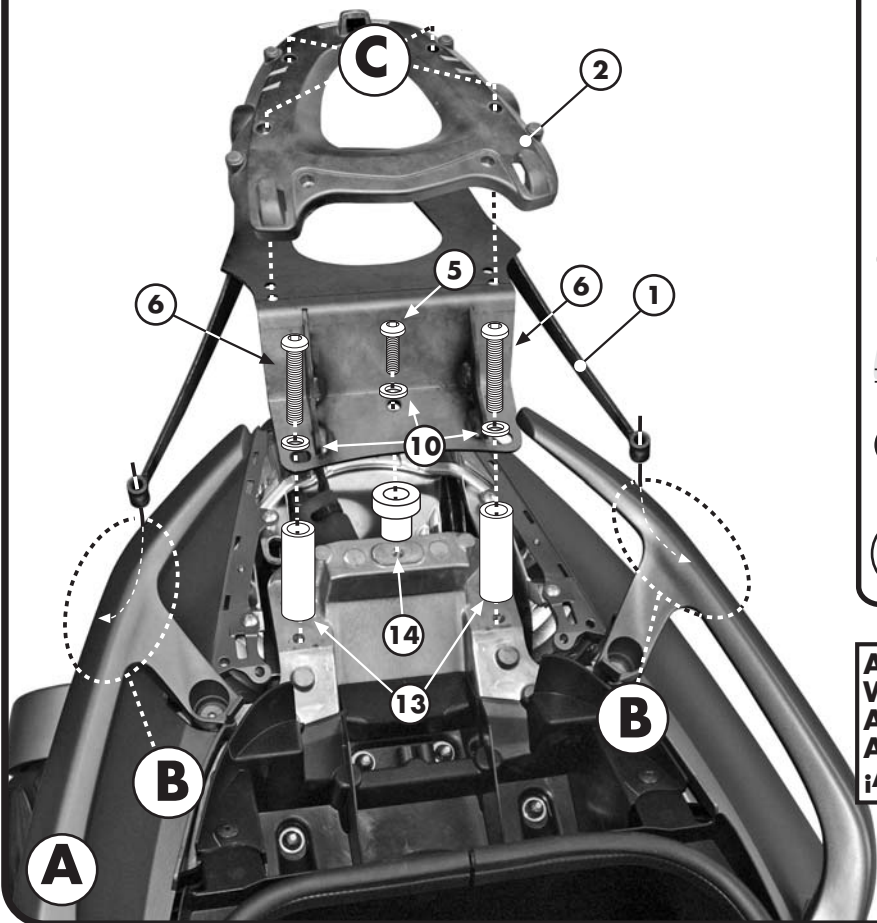

ATTENZIONE: CARICO MASSIMO 6Kg
WARNING: MAX LOAD, 6Kg.
ATTENTION: CHARGE MAXIMUM, 6Kg.
ACHTUNG: MAX, 6Kg.
¡ATENCIÓN!: CARGA MÁXIMA, 6Kg.

PORTAVALIGIA SPECIFICO - SPECIFIC CASE HOLDER
 PORTE-VALISE SPÉCIFIQUE - SPEZIFISCHER KOFFER-TRÄGER
 PORTA-EQUIPAJE ESPECÍFICO

YAMAHA T-MAX 500cc '08-'11
YAMAHA T-MAX 530cc 2012

ISTRUZIONI DI MONTAGGIO - MOUNTING INSTRUCTIONS
 INSTRUCTIONS DE MONTAGE - BAUANLEITUNG - INSTRUCCIONES DE MONTAJE

I ISTRUZIONI DI MONTAGGIO

1. SMONTARE IL CARTERINO POSTERIORE DELLO SCOOTER E FORARLO UTILIZZANDO LA DIMA RIPORTATA SUL FOGLIO 1;
2. SVITARE LE TRE VITI ORIGINALI SITUATE SOTTO IL CARTERINO;
3. POSIZIONARE I GOMMINI (PARTICOLARE N°9) E RIMONTARE IL CARTERINO;
4. POSIZIONARE IL SUPPORTO N°1 SEGUENDO IL MONTAGGIO PROPOSTO IN FIGURA A;
5. FISSARE IL SUPPORTO AI MANIGLIONI ORIGINALI COME INDICATO IN FIGURA B;
6. ULTIMARE IL MONTAGGIO CONTROLLANDO CHE LE VITI SIANO SERRATE BENE. (VITI M6=9,6 NM – VITI M8=23 NM).

GB MOUNTING INSTRUCTIONS

1. REMOVE THE SCOOTER'S REAR FAIRING PANEL AND DRILL HOLES IN IT USING THE TEMPLATE ON SHEET 1;
2. UNSCREW THE THREE ORIGINAL SCREWS FROM UNDER THE PANEL (SHOWN WHERE NEW BOLTS N°5 AND N°6 WILL GO) ;
3. INSTALL THE RUBBER GROMMETS (DETAIL N°9) AND RE-ATTACH THE REAR FAIRING PANEL;
4. INSTALL THE SUPPORT N°1 FOLLOWING THE DIAGRAM SHOWN IN PICTURE A;
5. ATTACH THE SUPPORT TO THE ORIGINAL GRAB HANDLES AS SHOWN IN PICTURE B;
6. MAKE SURE THAT ALL THE BOLTS ARE TIGHTENED APPROPRIATELY(M6 BOLTS=9.6Nm – M8 BOLTS=23Nm).

F INSTRUCTIONS DE MONTAGE

1. DEMONTER LE CAPOT POSTERIEUR DU SCOOTER ET LE PERCER EN UTILISANT LE GABARIT DE LA FEUILLE 1;
 2. DEVISSER LES TROIS VIS D'ORIGINE SOUS LE CARTER;
 3. METTRE LES CAOUTCHOUCS (PIECES N°9) ET REMONTER LE CAPOT;
 4. FIXER LE SUPPORT N°1 EN SUIVANT LE MONTAGE PROPOSE EN PHOTO A;
 5. FIXER LE SUPPORT AUX POIGNEES D'ORIGINE COMME INDIQUE EN PHOTO B;
- TERMINER LE MONTAGE EN CONTROLANT LE BON SERRAGE DE TOUTES LES VIS (VIS M6=9,6Nm – VIS M8=23Nm).

D BAUANLEITUNG

1. DEMONTIEREN SIE DAS HINTERE GEHÄUSE DES ROLLERS UND BOHREN SIE MIT HILFE DER SCHABLONE AUF SEITE 1 DIE VORGESEHENEN LÖCHER;
2. LÖSEN SIE DIE 3 ORIGINALSCHRAUBEN UNTER DEM GEHÄUSE;
3. POSITIONIEREN SIE DIE GUMMISTÖPSEL (POSITION NR. 9) UND MONTIEREN SIE DAS GEHÄUSE;
4. POSITIONIEREN SIE DIE HALTERUNG NR. 1 WIE IN DER MONTAGE DES BILDES A GEZEIGT;
5. BEFESTIGEN SIE DIE HALTERUNG AN DEN ORIGINAL HANDGRIFFEN WIE IM BILD B GEZEIGT;
6. ZULETZT ÜBERPRÜFEN SIE DASS ALLE SCHRAUBEN (SCHRAUBEN M6=9,6 NM – SCHRAUBEN M8=23 NM) FESTGEZOGEN WURDEN.

ES INSTRUCCIONES DE MONTAJE

1. DESMONTAR EL CARENADO POSTERIOR DEL SCOOTER Y PERFORARLO UTILIZANDO LA PLANTILLA DE LA HOJA 1;
2. QUITAR LOS TORNILLOS ORIGINALES COLOCADOS BAJO EL CARENADO.;
3. COLOCAR LAS GOMAS (REFERENCIA N.9) Y VOLVER A MONTAR EL CARENADO;
4. FIJAR EL SOPORTE N. 1 SIGUIENDO EL MONTAJE COMO SE MUESTRA EN LA FOTO A;
5. FIJAR LOS SOPORTES A LOS ASIDEROS ORIGINALES COMO SE MUESTRA EN LA FOTO B;
6. COMPLETAR EL MONTAJE VERIFICANDO QUE TODOS LOS TORNILLOS ESTEN BIEN APRETADOS (. (TORNILLOS M6=9,6 NM – TORNILLOS M8=23 NM).