



MODEL KAWASAKI ZX-6 R

YEAR 2009-

LINE SPORT

MUFFLER X-CONE PLUS

SCHEMATIC

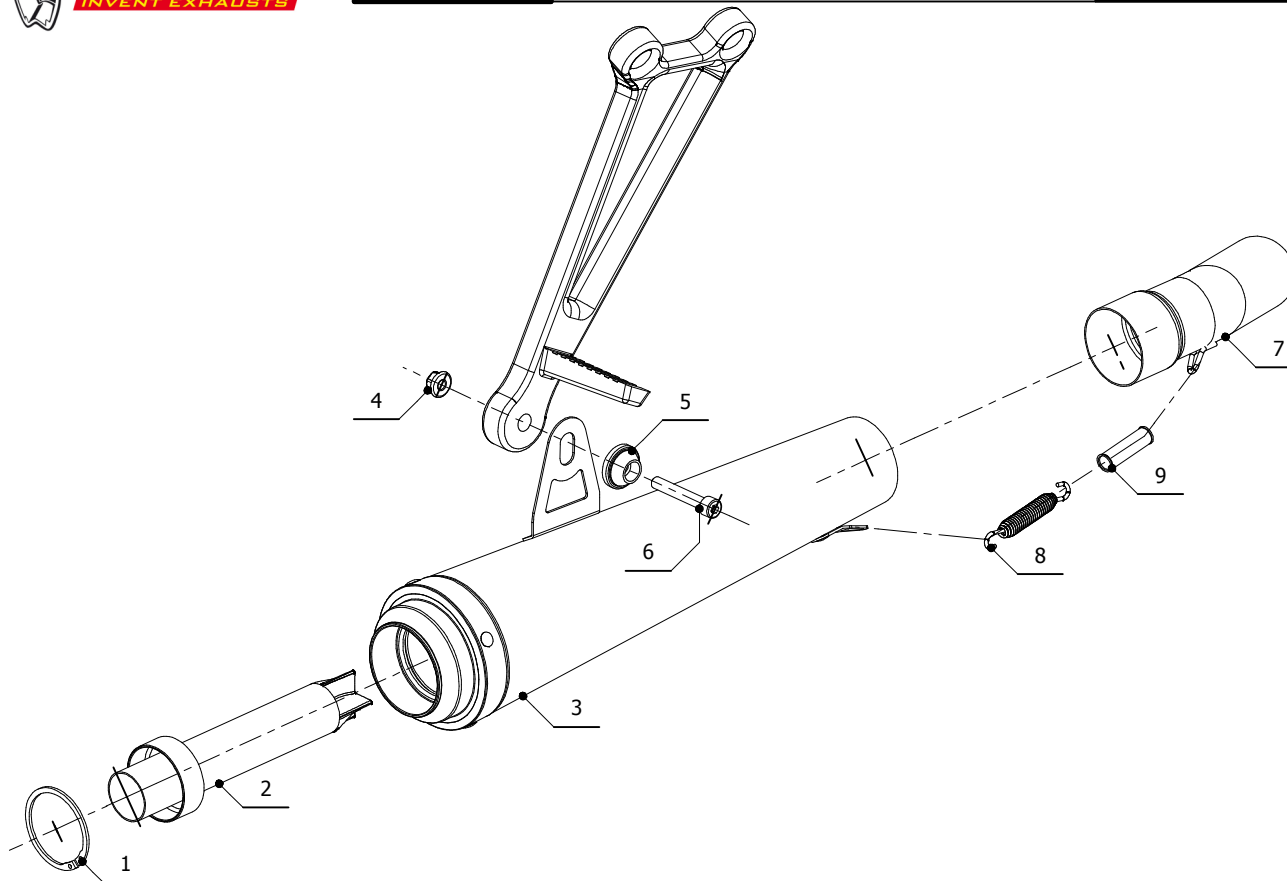

MONTAGGIO CAVI VALVOLA / THROTTLE CABLE ASSE

#	QTÀ / QTY	DESCRIZIONE / DESCRIPTION	CODICE / CODE
10	1	Staffa / Bracket	50.73.787.0
11	4	Grani M3 / Grub screws M3	50.73.140.1
12	2	Morsetti in alluminio / Aluminium clamps	50.73.138.1
13	2	Molla / Spring	50.73.142.1

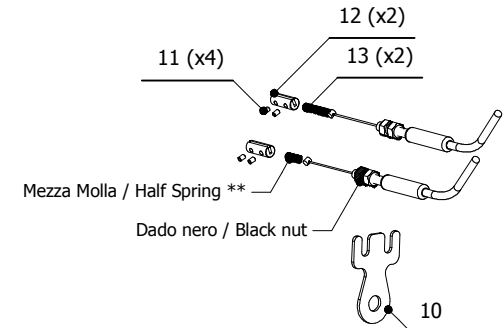

\*\* La molla da inserire sul cavo con il dado nero deve essere tagliata a metà  
 \*\* The spring to insert on the cable with black nut must be cut in half

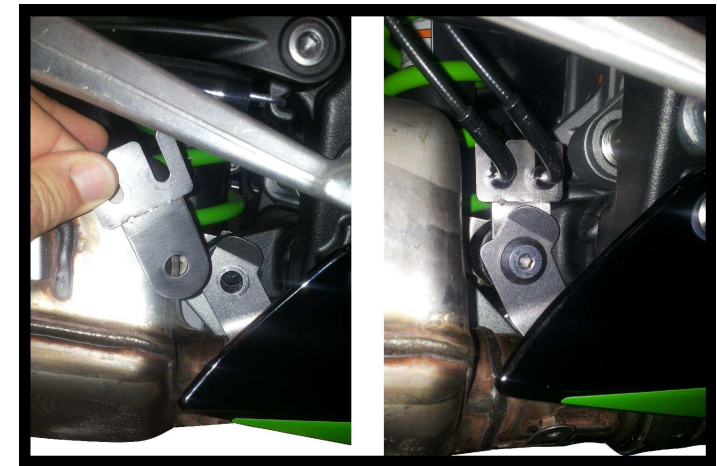

ELENCO PARTI / PARTS LIST

#	QTÀ / QTY	DESCRIZIONE / DESCRIPTION	CODICE / CODE
1	1	Anello Seger / Seger ring	50.73.218.1
2	1	Db killer forato / Drilled DB killer	50.DK.030.0
3	1	Silenziatore / Muffler	X-cone Plus
4	1	Dado M8 flangiato / Flanged nut M8	50.73.393.1
5	1	Rondella alluminio / Aluminium washer	50.73.291.1
6	1	Vite M8x50 / Screw M8x50	50.73.074.1
7	1	Tubo di raccordo / Link pipe	9773K021S2
8	1	Molla lunga / Long spring	50.71.080.1
9	1	Tubo in gomma per molla / Rubber pipe for spring	50.73.210.1

APPLICAZIONI / APPLICATIONS

CODICE / CODE	TUBO / PIPE	MUFFLER / SILENZIATORE	FASCETTA / CLAMP
K.022.LP3	INOX / ST. STEEL	INOX / ST. STEEL	///