

PARAMOTORE SPECIFICO - SPECIFIC ENGINE GUARD - PARE-CARTER SPECIFIQUE
 SPEZIFISCHER STURZBÜGEL - DEFENSA DE MOTOR ESPECIFICA

SUZUKI GSR600 2006

ISTRUZIONI DI MONTAGGIO - MOUNTING INSTRUCTIONS
 INSTRUCTIONS DE MONTAGE - BAUANLEITUNG - INSTRUCCIONES DE MONTAJE



1
 PARAMOTORE
 ENGINE GUARD
 PARE-CARTER
 STURZBÜGEL
 DEFENSA DE MOTOR

Q.TY n.2 (dx-sx)

2



NIPPLES

Q.TY n.1

3



DISTANZIALE Ø14x20mm
 Foro Ø8,5mm, V009

SPACER
 ENTRETOISE
 DISTANZSTÜCK
 DISTANCIADOR

Q.TY n.1

4



DISTANZIALE Ø24x18mm
 Foro Ø10,5mm, V618

SPACER
 ENTRETOISE
 DISTANZSTÜCK
 DISTANCIADOR

Q.TY n.1

5



DISTANZIALE Ø24x26mm
 Foro Ø10,5mm, V619

SPACER
 ENTRETOISE
 DISTANZSTÜCK
 DISTANCIADOR

Q.TY n.1

6

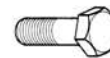

VITE TE M10x40mm
 Passo 1,25mm
 SCREW M10x40mm
 VIS M10x40mm
 SCHRAUBE M10x40mm
 TORNILLO M10x40mm

Q.TY n.2

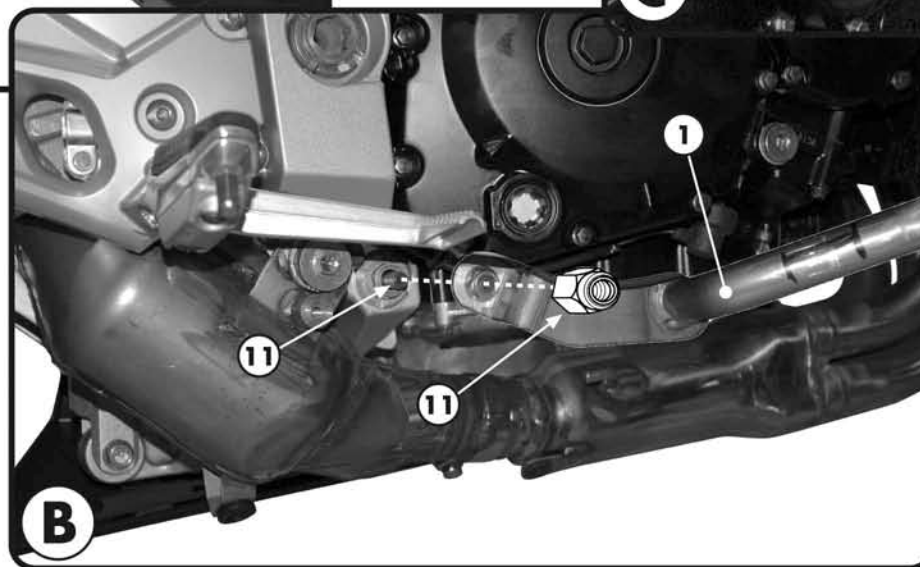
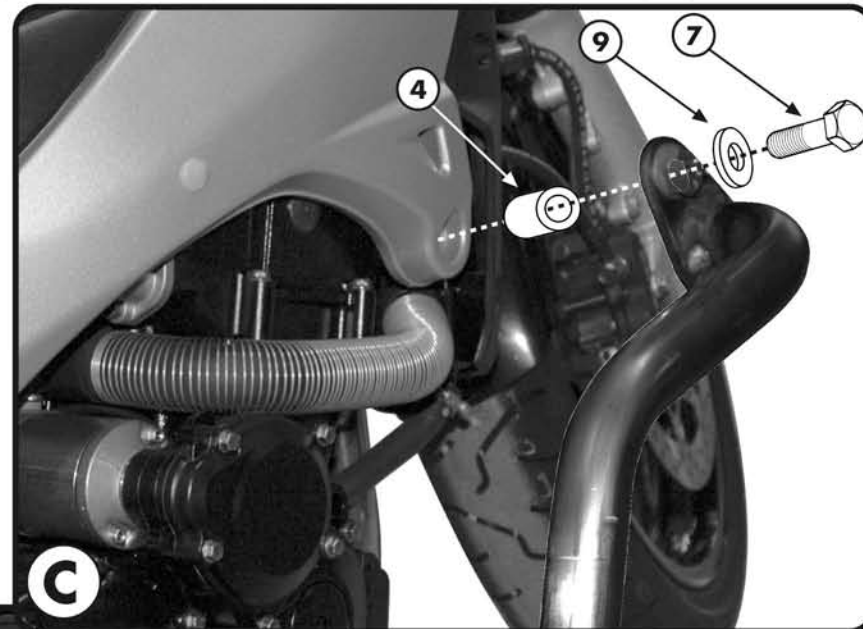

SI RACCOMANDA DI FARE ESEGUIRE IL MONTAGGIO AD UN MECCANICO QUALIFICATO

WE RECOMMEND THAT THE MOUNTING IS CARRIED OUT BY A QUALIFIED MOTORCYCLE MECHANIC

IL EST RECOMMANDE DE FAIRE EXECUTER LE MONTAGE PAR UN MECANICIEN QUALIFIE

WIR EMPFEHLEN, DAß DIE MONTAGE VON EINEM FACHMECHANIKER DURCHFÜHRT WIRD

LES RECOMENDAMOS QUE EL MONTAJE DE LA DEFENSA SE REALICE POR UN MECANICO CALIFICADO

PARAMOTORE SPECIFICO - SPECIFIC ENGINE GUARD - PARE-CARTER SPECIFIQUE
 SPEZIFISCHER STURZBÜGEL - DEFENSA DE MOTOR ESPECIFICA

SUZUKI GSR600 2006

ISTRUZIONI DI MONTAGGIO - MOUNTING INSTRUCTIONS
 INSTRUCTIONS DE MONTAGE - BAUANLEITUNG - INSTRUCCIONES DE MONTAJE

7

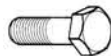

VITE TE M10x65mm
 Passo 1,25mm
 SCREW M10x65mm
 VIS M10x65mm
 SCHRAUBE M10x65mm
 TORNILLO M10x65mm

Q.TY n.1

8

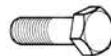

VITE TE M10x85mm
 Passo 1,25mm
 SCREW M10x85mm
 VIS M10x85mm
 SCHRAUBE M10x85mm
 TORNILLO M10x85mm

Q.TY n.1

9



RONDELLA Ø10mm
 WASHER Ø10mm
 RONDELLE Ø10mm
 SCHEIBE Ø10mm
 ARANDELA Ø10mm

Q.TY n.4

10



RONDELLA Ø8mm
 WASHER Ø8mm
 RONDELLE Ø8mm
 SCHEIBE Ø8mm
 ARANDELA Ø8mm

Q.TY n.1

11

COMPONENTI ORIGINALI
 ORIGINAL PARTS
 PARTIES ORIGINALES
 ORIGINAL BAUTEILE
 COMPONENTES ORIGINALES

Q.TY n.-

12

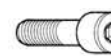

VITE TCEI M8x35mm
 SCREW M8x35mm
 VIS M8x35mm
 SCHRAUBE M8x35mm
 TORNILLO M8x35mm

Q.TY n.1

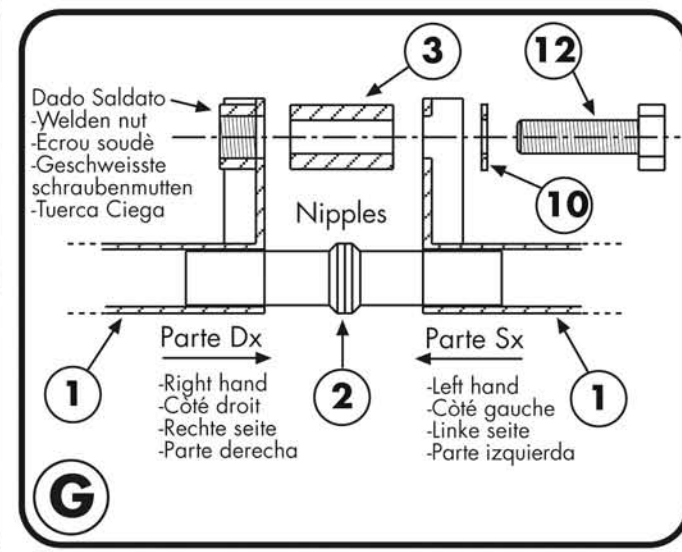
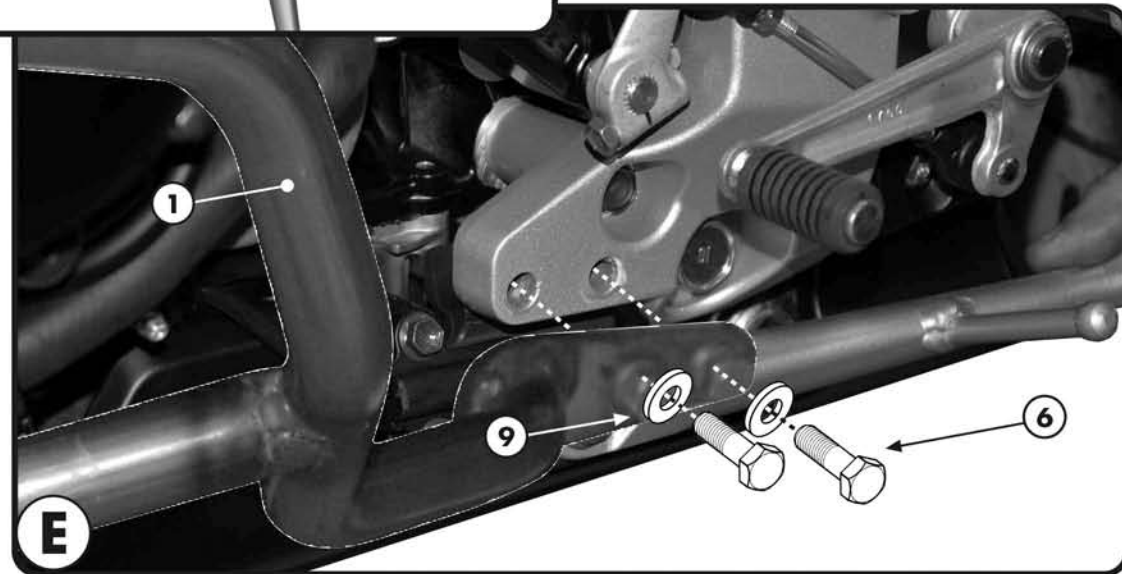
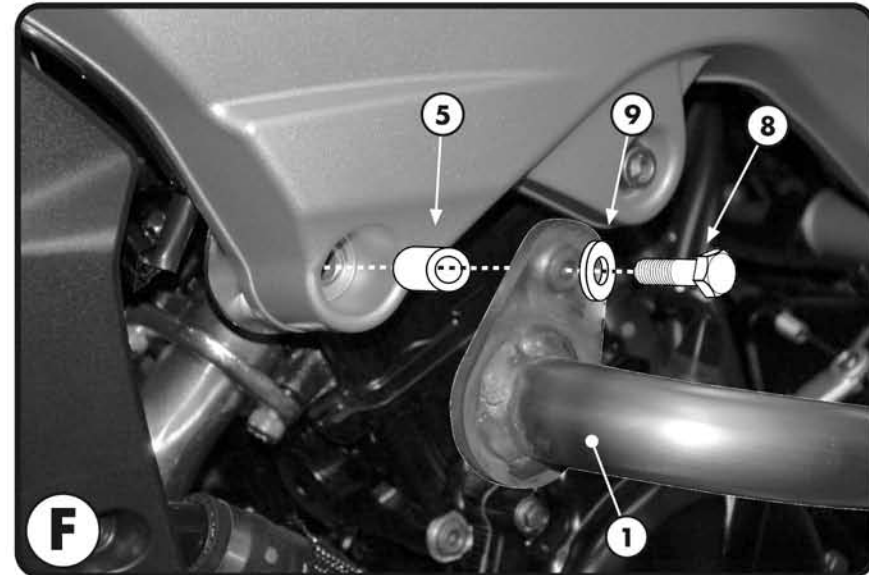
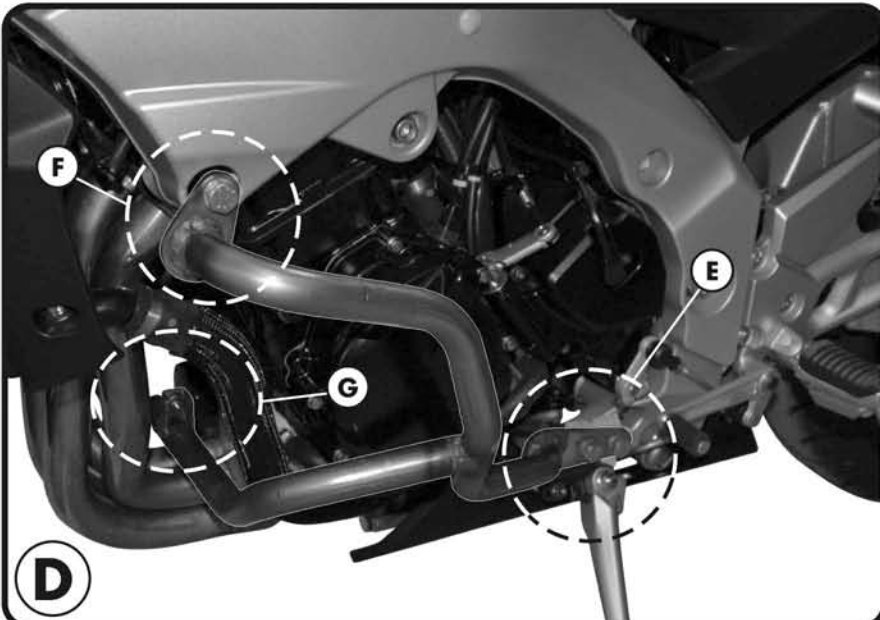

PARAMOTORE SPECIFICO - SPECIFIC ENGINE GUARD - PARE-CARTER SPECIFIQUE
 SPEZIFISCHER STURZBÜGEL - DEFENSA DE MOTOR ESPECIFICA

SUZUKI GSR600 2006

ISTRUZIONI DI MONTAGGIO - MOUNTING INSTRUCTIONS
 INSTRUCTIONS DE MONTAGE - BAUANLEITUNG - INSTRUCCIONES DE MONTAJE

I ISTRUZIONI DI MONTAGGIO

1. PER FACILITARE IL MONTAGGIO DEL LATO DESTRO DEL PARAMOTORE SI CONSIGLIA DI SMONTARE LA PARTE DESTRA DEL PUNTALE ORIGINALE DELLA MOTOCICLETTA, VEDI FOTOGRAFIA A;
2. POSIZIONARE IL PARAMOTORE COME INDICATO IN FOTOGRAFIA A PER LA PARTE DESTRA E IN FOTOGRAFIA D PER LA PARTE SINISTRA; FAR RIFERIMENTO ALLE RISPETTIVE FOTOGRAFIE PER I MONTAGGIO DEI VARI PUNTI;
3. RICORDARSI DI RIMONTARE LA PARTI ORIGINALI EVENTUALMENTE TOLTE PER FACILITARE IL MONTAGGIO DEL PARAMOTORE;
4. ULTIMARE IL MONTAGGIO CONTROLLANDO CHE TUTTE LE VITI SIANO SERRATE BENE.

GB MOUNTING INSTRUCTIONS

1. IN ORDER TO SIMPLIFY THE MOUNTING OF THE RIGHT SIDE OF THE ENGINE GUARD WE SUGGEST DEMOUNTING THE RIGHT ORIGINAL RADIATOR SCOOP, SEE PICTURE A;
2. PLACE THE ENGINE GUARD AS SHOWN IN PICTURE A FOR THE RIGHT SIDE AND IN PICTURE D FOR THE LEFT SIDE; MAKE REFERENCE TO THE TWO PICTURES FOR THE MOUNTING OF THE DIFFERENT LOCATIONS;
3. REMOUNT THE ORIGINAL REMOVED PARTS IN ORDER TO COMPLETE THE MOUNTING OF THE ENGINE GUARD;
4. LASTLY CHECK THAT ALL SCREWS HAVE BEEN TIGHTENED.

F INSTRUCTIONS DE MONTAGE

1. POUR FACILITER LE MONTAGE DU PARE CARTER DROIT, IL EST PREFERABLE DE DEMONTER LA PARTIE DROITE DU SABOT MOTEUR D'ORIGINE DE LA MOTO, VOIR PHOTO A;
2. POSITIONNER LE PARE CARTER COMME INDIQUE EN PHOTO A POUR LE COTE DROIT ET EN PHOTO D POUR LE COTE GAUCHE; SE REFERER AUX DIFFERENTES PHOTOS POUR LES POINTS DE FIXATION SPECIFIQUES;
3. NE PAS OUBLIER DE REMONTER LES PIECES D'ORIGINE PRECEDEMMENT ENLEVEES POUR FACILITER LE MONTAGE DES PARE CARTERS;
4. FINIR LE MONTAGE EN CONTROLANT LE BON SERRAGE DE TOUTES LES VIS.

D BAUANLEITUNG

1. UM DIE MONTAGE DER RECHTEN SEITE DES STURZBÜGEL ZU ERLEICHTERN, EMPFEHLEN WIR DIE RECHTE SEITE DES ORIGINAL BUGSPOILERS, BILD A, ABZUMONTIEREN;
2. POSITIONIEREN SIE DEN STURZBÜGEL WIE IM BILD A BESCHRIEBEN F,R DIE RECHTE SEITE UND WIE IM BILD D BESCHRIEBEN F,R DIE LINKE SEITE; NEHMEN SIE AUF BEIDE BILDER BEZUG F,R DIE MONTAGE DER VERSCHIEDENEN PUNKTEN;
3. MONTIEREN SIE DIE ORIGINAL TEILE WIEDER AN, DIE SIE AM ANFANG ABMONTIERT HATTEN;
4. ZULETZT BERÜCKSICHTIGEN SIE, DASS ALLE SCHRAUBEN FESTGEZOGEN WURDEN.

ES

INSTRUCCIONES DE MONTAJE

1. PARA FACILITAR EL MONTAJE DEL LADO DERECHO DE LAS DEFENSAS DE MOTO SE ACONSEJA DESMONTAR LA PARTE DERECHA DEL PUNTALE ORIGINAL DE LA MOTOCICLETA, TAL Y COMO SE INDICA EN LA FOTOGRAFIA A.
2. POSICIONAR LAS DEFENSAS DE MOTOR TAL Y COMO SE MUESTRA EN LA FOTOGRAFIA A PARA LA PARTE DERECHA Y EN LA FOTOGRAFIA D PARA LA PARTE IZQUIERDA; HACE REFERENCIA A LAS RESPECTIVAS FOTOGRAFIAS PARA EL MONTAJE DE LOS VARIOS PUNTOS.
3. NO OLVIDAR VOLVER A MONTAR LAS PARTES ORIGINALES EVENTUALMENTE DESMONTADAS PARA FACILITAR EL MONTAJE DE LAS DEFENSAS DE MOTOR.
4. ULTIMAR EL MONTAJE CONTROLANDO QUE TODOS LOS TORNILLOS ESTEN BIEN AJUSTADOS.